

## Earth-Rite® FIBC

Static grounding protection for Type C FIBC located in potentially flammable/combustible gas or dust atmospheres



The **Earth-Rite® FIBC** system validates and monitors the resistance of Type C FIBC bags ensuring that the conductive elements of the bag are capable of dissipating electrostatic charges in compliance with IEC 61340-4-4 “Standard test methods for specific applications - Electrostatic classification of flexible intermediate bulk containers (FIBC)” and NFPA 77 “Recommended Practice on Static Electricity”.

**Enquiry** > Click here to submit a product related query or a request for quotation.

The **Earth-Rite FIBC** system can be installed and setup to ensure that operators ground the bag before filling or emptying operations are started. During the bag filling / emptying process the Earth-Rite FIBC system continuously monitors the resistance of the bag so that if it rises above the recommended level of  $1 \times 10^7$  ohms (10 meg-ohm) this dangerous situation can be indicated to operators and the process halted, either manually or via the system's pair of NO/NC volt free contacts.

This feature ensures the generation and accumulation of static charges on the bag is stopped eliminating the risk of an incendive electrostatic spark discharge.

To compensate for normal wear and tear on Type C bags it is important to ensure the bag maintains its capacity to dissipate charge and also ensure the ground connection between the bag and plant earth grounding point is functioning correctly.

Newson Gale can also provide FIBC grounding systems that can validate and monitor Type C bags designed with an upper resistance threshold of  $1 \times 10^8$  ohms (100 meg-ohm).



**Earth-Rite FIBC** Type C Static Grounding System

### The Earth-Rite FIBC includes:

- > SDP Controller (static dissipative GRP) with Intrinsically Safe Monitoring Circuits.
- > FIBC Grounding Clamp with single conductor Hytel® Protected Cable.
- > Junction Box with Stowage Pin for stowing FIBC Grounding Clamp.

**Earth-Rite® FIBC** Static grounding protection for Type C FIBC located in potentially flammable/combustible gas or dust atmospheres

**Features and Benefits**

**Attention grabbing LEDs**

Three green LEDs continuously pulse informing operators that the FIBC bag to be protected from static discharges is correctly grounded. When the system is not in use, or when it detects the resistance in the static dissipative loop is higher than  $1 \times 10^7$  ohms, a red LED illuminates the indicator panel located in the static dissipative GRP indicator station.

**Continuous Ground Loop Monitoring**

Monitors the resistance of the static dissipative loop through the FIBC bag back to the Earth-Rite FIBC via the plant earth grounding point. If the system detects that resistance in the loop is higher than  $1 \times 10^7$  ohms, it engages a pair of output contacts.

**Two volt free output contacts**

The primary contact can interlock with electro-mechanical devices or PLC systems to shutdown the flow of product. The secondary contact can interface with attention grabbing audible alarms or strobe lights to provide an extra degree of safety over the hazard.

**Easy Installation**

Simple to mount GRP enclosures complemented by straightforward cabling and PCB system wiring. Flexible hazardous area enclosure location options with separate IS monitoring / indicator and Power supply PCBs. Power supply PCB can run off both 240 V and 110 V mains / line supply and 24 V / 12 V DC voltage supply.

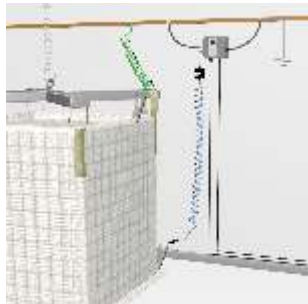

**The Earth-Rite FIBC** ensures Type C FIBC bags are protected from incendive electrostatic discharges during bag filling and discharging operations.



**The Earth-Rite FIBC** can be installed in Zoned / Classified combustible dust atmospheres. If gas and vapour atmospheres are present an Ex(d) / XP, Zone 1 / Class I, Div. 1 system may be specified.



**X45F FIBC stainless steel grounding clamp** with Quick Connect and optional lengths of Hytrel protected single core cable included.

- > IEC 60079-32, IEC 61340-4-4 and NFPA 77, state that the resistance through a Type C FIBC bag should not exceed  $1 \times 10^7$  ohms (10 meg-ohm).
- > CLC/TR: 50404, which was superseded by IEC 60079-32, states that the resistance through a Type C FIBC bag should not exceed  $1 \times 10^8$  ohms (100 meg-ohm).

**Options**

- Ex(d)XP Flameproof enclosure for gas & vapour atmosphere.
- A 2nd clamp connects FIBC bag to verified earth grounding point.
- Explosion Proof Strobe Light
- IEC/Cenelec (European) and NEC/CEC (North American) versions available

**Certification**



**Ingress Protection**  
IP 66

**Temperature Range**  
-40°C to +55°C - ATEX / IECEx  
-13°F to +122°F - CSA

**Power Supply**

110/120 V or 220/240 V AC, 50-60 Hz, 12 V or 24 V DC

The Earth-Rite® FIBC forms part of the Earth-Rite® range of Static Grounding and Bonding Equipment available from Newson Gale.

**Earth-Rite® FIBC** Static grounding protection for Type C FIBC located in potentially flammable/combustible gas or dust atmospheres

**Technical Specification**

GRP (Class I, II, III - Div. 2 Installations)

Power Supply & Monitoring-Unit	
<b>Power supply (AC version)</b>	108/125 V or 216/250 V AC, 50-60 Hz 12 V or 24 V DC
<b>Power rating</b>	10 watt
<b>Ambient temperature range</b>	-13°C to +131°C
<b>Ingress protection</b>	Type 4X (IP 66)
<b>Weight</b>	3.3 lbs (1.5 Kg) nett
<b>Construction</b>	Carbon-Loaded GRP
<b>Monitoring circuit</b>	Intrinsically safe
<b>Operational series ground resistance</b>	$\leq 1 \times 10^6$ or $1 \times 10^7$ Ohm
<b>Output Relay Contacts Rating</b>	2 dry contacts, 250 V AC, 5 A, 500 VA max resistive, 30 V DC, 2 A, 60 W max resistive
<b>Cable Entries</b>	7 x M20 (4 x plugged)

Junction Box/Stowage Point	
<b>Enclosure Material</b>	GRP with carbon loading
<b>Terminals</b>	2 x AWG #14 conductor capacity
<b>Stowage Device</b>	Insulated 0.19" diameter pin
<b>Cable Entries</b>	1 x M20
<b>Clamp Cable Connection</b>	Quick Connect

Grounding Clamp	
<b>Clamp Design</b>	1 pole with single stainless steel contact
<b>Body</b>	Stainless Steel (SS 304)
<b>Certification</b>	Ex II 1 GD T6
<b>Approval</b>	FM Approved

Spiral Cable	
<b>Cable</b>	Blue Cen-Stat Hytel sheath (Static dissipative, chemical & abrasion resistant)
<b>Conductors</b>	1 x AWG #12 steel
<b>Length</b>	5 metres extended, 1 metre unextended (other lengths available, please inquire)

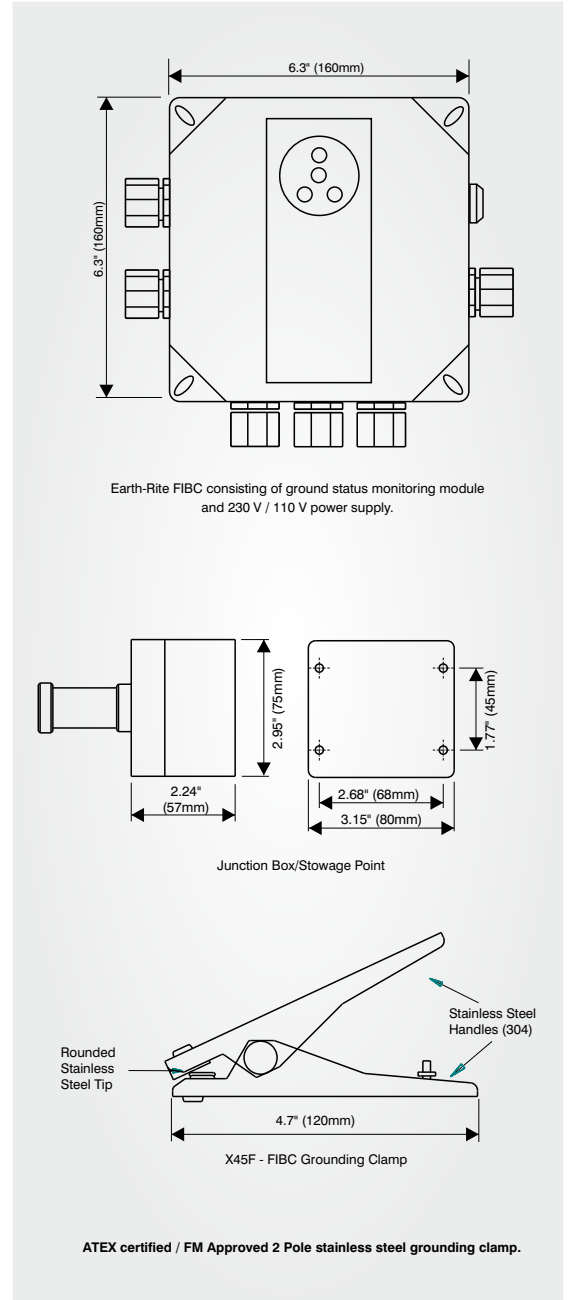

**Earth-Rite® FIBC** Static grounding protection for Type C FIBC located in potentially flammable/combustible gas or dust atmospheres

## Hazardous Area Certification

Europe / International:	North America:
<p><b>IECEX</b>                      Ex nA nC [ia] IIC T4 Gc(Ga) (gas &amp; vapour).                      Ex tb IIIC T70°C Db (combustible dusts).                      Ta = -40°C to +55°C.                      IECEX SIR 09.0097                      IECEX certifying body: SIRA.</p> <p><b>ATEX</b>                      Ex II 3(1) G                      Ex II 2D                      Ex nA nC [ia] IIC T4 Gc(Ga)                      Ex tb IIIC T70°C Db                      Ta = -40°C to +55°C.                      Sira 09ATEX2247                      ATEX Notified Body: SIRA.</p>	<p><b>NEC 500 / CEC (Class &amp; Division)</b>                      Associated Equipment [Ex ia] for use in                      Class I, Div. 2, Groups A, B, C, D;                      Class II, Div. 2, Groups E, F, G                      Class III, Div. 2,                      Providing Intrinsically Safe circuits for                      Class I, Div. 1, Groups A, B, C, D;                      Class II, Div. 1, Groups E, F, G;                      Class III, Div. 1;                      When installed per Control Dwg;                      ERIL-Q-10165 cCSAus                      Ta = -25°C to +55°C.                      Ta = -13°F to +131°F.</p> <p>OSHA recognised NRTL: CSA.</p> <p><b>NEC 505 &amp; 506 (Class &amp; Zoning)</b>                      Class I, Zone 2, (Zone 0), AEx nA[ia] IIC T4                      (gas &amp; vapour).                      Class II, Zone 21, AEx tD[iaD] 21, T70°C,                      (combustible dusts).</p> <p><b>CEC Section 18 (Class &amp; Zoning)</b>                      Class I, Zone 2 (Zone 0) Ex nA[ia] IIC T4                      DIP A21, IP66, T70°C</p>

## Additional Certification

<b>Safety Integrity Level:</b>	SIL 2 (in accordance with IEC/EN 61508).
<b>SIL assessment body:</b>	Exida
<b>EMC Tested:</b>	to EN 61000-6-4, EN 61000-6-2 FCC - Part 15 (Class B)



**Earth-Rite® FIBC** Static grounding protection for Type C FIBC located in potentially flammable/combustible gas or dust atmospheres

**Technical Specification**

XP (Class I, II, III - Div. 1 Installations)

Monitoring unit	
<b>Power supply</b>	110/120 V or 220/240 V AC, 50-60 Hz 12 V or 24 V DC
<b>Power rating</b>	10 watt
<b>Ambient temperature range</b>	-13°F to +122°F
<b>Ingress protection</b>	Type 4X (IP 66)
<b>Weight</b>	9.9 lbs (4.5 kg) nett
<b>Construction</b>	Copper-free cast aluminium
<b>Monitoring Circuit</b>	Intrinsically Safe
<b>Operational Series Ground Resistance</b>	$\leq 1 \times 10^8$ or $1 \times 10^7$ Ohm
<b>Output Relay Contact Rating</b>	2 off dry contacts, 250 V AC, 5 A, 500 VA max resistive 30 V DC, 2 A, 60 W max resistive
<b>Cable Entries</b>	7 x 3/4" NPT (supplied with 4 stopper plugs)
Junction Box/Stowage Point	
<b>Enclosure Material</b>	GRP with carbon loading
<b>Terminals</b>	2 x AWG #14 conductor capacity
<b>Stowage Device</b>	Insulated 0.79" diameter pin
<b>Cable Entries</b>	1 x M20
<b>Clamp Cable Connection</b>	Quick Connect
Grounding Clamp	
<b>Clamp Design</b>	1 pole with single stainless steel contact
<b>Body</b>	Stainless Steel
<b>Certification</b>	Ex II GD T6
<b>Approval</b>	FM Approved
Spiral Cable	
<b>Cover</b>	Cover Blue Cen-Stat Hytrel sheath (Static dissipative, chemical & abrasion resistant)
<b>Conductors</b>	1 x AWG #12 steel
<b>Length</b>	16 ft (5m) extended, 3 ft (1m) unextended (other lengths available - please inquire)

**Mechanical Installation Data**

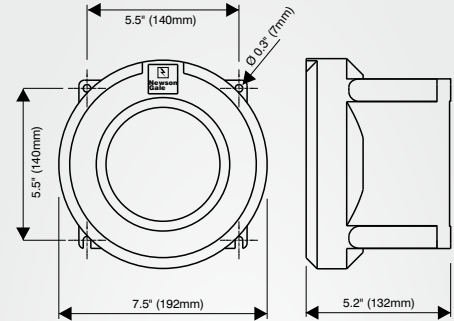

Approved copper free cast aluminium enclosure - IP 66 / Type 4X

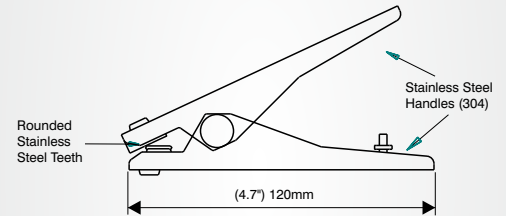

X45F - FIBC Grounding Clamp

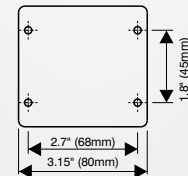
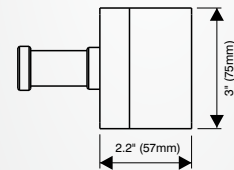

Simple Apparatus GRP clamp stowage box with grounding clamp stowage pin

**Earth-Rite® FIBC** Static grounding protection for Type C FIBC located in potentially flammable/combustible gas or dust atmospheres

## Hazardous Area Certification

Europe / International:	North America:
<p><b>IECEX</b>                      Ex d[ia] IIC T6 Gb(Ga) (gas &amp; vapour).                      Ex tb IIIC T80°C IP66 Db (combustible dusts).                      Ta = -40°C to +55°C.                      IECEX SIR 09.0018                      IECEX certifying body: SIRA.</p> <p><b>ATEX</b>                      II 2(1)GD                      Ex d[ia] IIC T6 Gb(Ga)                      Ex tb IIIC T80°C IP66 Db                      Ta = -40°C to +55°C.                      Sira 09ATEX2047                      ATEX Notified Body: SIRA.</p>	<p><b>NEC 500 / CEC (Class &amp; Division)</b>                      Associated Equipment [Ex ia] for use in                      Class I, Div. 1, Groups A, B, C, D;                      Class II, Div. 1, Groups E, F, G;                      Class III, Div. 1,                      Providing intrinsically safe circuits for                      Class I, Div. 1, Groups A, B, C, D;                      Class II, Div. 1, Groups E, F, G;                      Class III, Div. 1,                      When installed per Control Dwg:                      ERII-Q-10110 cCSAus                      Ta = -25°C to +50°C.                      Ta = -13°F to +122°F.</p> <p>OSHA recognised NRTL: CSA.</p> <p><b>NEC 505 &amp; 506 (Class &amp; Zoning)</b>                      Class I, Zone 1 [0] AEx d[ia] IIC T6 Gb(Ga)                      (gas &amp; vapour).                      Class II, Zone 21 [20] AEx tD [iaD] 21 T80°C                      (combustible dusts).</p> <p><b>CEC Section 18 (Class &amp; Zoning)</b>                      Class I, Zone 1[0] Ex d[ia] IIC T6 Gb(Ga)                      DIP A21, IP66, T80°C</p>

## Additional Certification

<b>Safety Integrity Level:</b>	SIL 2 (in accordance with IEC/EN 61508).
<b>SIL assessment body:</b>	Exida
<b>EMC Tested:</b>	to EN 61000-6-4, EN 61000-6-2 FCC - Part 15 (Class B)



**Earth-Rite® FIBC** Static grounding protection for Type C FIBC located in potentially flammable/combustible gas or dust atmospheres

## System Options

Newson Gale supplies a range of product options that enhance the control and general safety of transfer processes and aid engineers with system installations and routine system service checks. Contact Newson Gale or your local Newson Gale representative for more information on the range of options available.

### Universal Resistance Tester

The URT is designed to provide owners of Newson Gale **Earth-Rite®** and **Bond-Rite®** static grounding systems with a means of regularly testing the grounding settings for their system on a routine basis.

Periodic testing with the URT verifies that the grounding system's **GO/NO GO** settings are working in compliance with the recommendations of:

**NFPA 77:** "Recommended Practice on Static Electricity."

**IEC 60079-32-1:** "Explosive atmospheres. Part 32-1: Electrostatic hazards, guidance."

The easy to use tester consists of a pair of rotary switches that enable a competent electrical person to check the resistance level at which the grounding system should be working and conduct a **PASS / FAIL** test at the required setting.

**Earth-Rite®** and **Bond-Rite®** products that can be tested with the URT:

- > Earth-Rite® PLUS
- > Earth-Rite® FIBC (both 10 meg-ohm and 100 meg-ohm variants)
- > Bond-Rite® CLAMP
- > Bond-Rite® EZ
- > Bond-Rite® REMOTE
- > OhmGuard® (both 10 ohm and 100 ohm variants).



**Universal Resistance Tester**  
Product Code: URT.



**Earth-Rite® FIBC** Static grounding protection for Type C FIBC located in potentially flammable/combustible gas or dust atmospheres

**Inquiry** > Click here to submit a product related query or a request for quotation.

## Application Spotlight Type C FIBCs

Type C bags are designed to dissipate static electricity through static dissipative threads that are interwoven through the bag's material.

Grounding tabs located on the bags are points where grounding systems can be connected to ensure static electricity does not accumulate on the bag. To ensure bags destined for use in hazardous areas will not accumulate static electricity to hazardous levels there are several standards that provide guidance on the key parameters to which Type C bags must comply.

The primary standard is IEC 61340-4-4, *"Electrostatics – Part 4-4: Standard test methods for specific applications – Electrostatic classification of flexible intermediate bulk containers (FIBC)."* This standard was released in the early part of 2012 and it sets out the essential requirements of Type C bags in relation to eliminating the risk of charge accumulation on the bag. It states that the resistance through the bag should be less than  $1 \times 10^7$  ohms (10 meg-ohm). This means that the resistance from a point on the bag to a grounding tab should never be higher than 10 meg-ohm. The latest edition of NFPA 77, *"Recommended Practice on Static Electricity"*, recommends this value of resistance.

This standard is set to supersede the recommendations contained in the 2003 CENELEC technical report, called CLC/TR 50404 which stipulates a maximum value of  $1 \times 10^8$  ohms (100 meg-ohms). The latest edition of **TRBS 2153:2009** recommends the same value of resistance.

### Checking and grounding Type C bags.

When a company wishes to utilise Type C bags they must provide a means for grounding the bag. This can be achieved with either passive (single pole clamp and cable) or active means (monitoring systems), but given the scale of the charge that can build up on bags and the resulting energies that can be reached by static sparks, in combination with the presence of a combustible dust cloud, an active grounding system is the better choice.

This is because the system can determine whether or not the bag's construction complies with the recommendations of the standards highlighted above and will also ensure the bag is grounded for the duration of the filling / emptying operation. The primary benefit of checking the resistance through the bag is to ensure that after many cycles of repeated use, the static dissipative threads are functioning correctly and, more importantly, to ensure that bags not of Type C construction are not permitted to be used in the hazardous area. Additional benefits with grounding systems are that they can control the movement of the powder through output contacts interlocked with valves or PLCs.



### Helpful Tips for correctly grounding Type C FIBC bags:

- > Ensure Type C bags are manufactured in accordance with the electrostatic recommendations of IEC 61340-4-4 / NFPA 77 or CLC/TR: 50404.
- > Ensure that the grounding system selected can check and continuously monitor the full range of resistance through the bag.
- > Ensure the grounding system not only checks the condition of the bag's static dissipative threads, but also ensure that the ground circuit includes a direct and monitored connection to a verified True Earth grounding point.
- > Ensure the grounding system does not monitor a limited percentage of the permitted range of resistance as they may pass faulty bags and reject acceptable bags.



**Earth-Rite® FIBC** Static grounding protection for Type C FIBC located in potentially flammable/combustible gas or dust atmospheres

The illustration highlights how a bag can be checked for its static dissipative capability in combination with providing active grounding of the bag. Following the connection of two quick release clamps, the Earth-Rite® FIBC system will identify if the bag is operating in accordance with the relevant standard. This is achieved by sending an Intrinsically Safe (Hazloc approved) signal (red line in the illustration) through the bag. If the green ground status indicators pulse continuously, the operators know the bag is grounded. The system verifies the grounding of the bag by ensuring the signal returns via a verified true earth ground. If there is any charge on the bag it will leave the bag via the static dissipative threads to the verified ground. If the output contacts are interlocked with the process then the material cannot flow without the permission of the operator.

**Are the Type C FIBCs 10 meg-ohm or 100 meg-ohm bags?**

The primary question to address when selecting a Type C FIBC grounding system is to determine which standard the bags in use are constructed to. Although bags manufactured in accordance with the 10 meg-ohm requirement are growing in number, there is a significant percentage of Type C FIBCs manufactured in accordance with the 100 meg-ohm requirement.

If the company is committed to using CENELEC compliant 100 meg-ohm Type C bags then the grounding system should monitor the full range of resistance.

This ensures that bags of different static dissipative consistency can be checked and monitored for the full permissive range of resistance. Any bags operating outside of this range should be rejected.

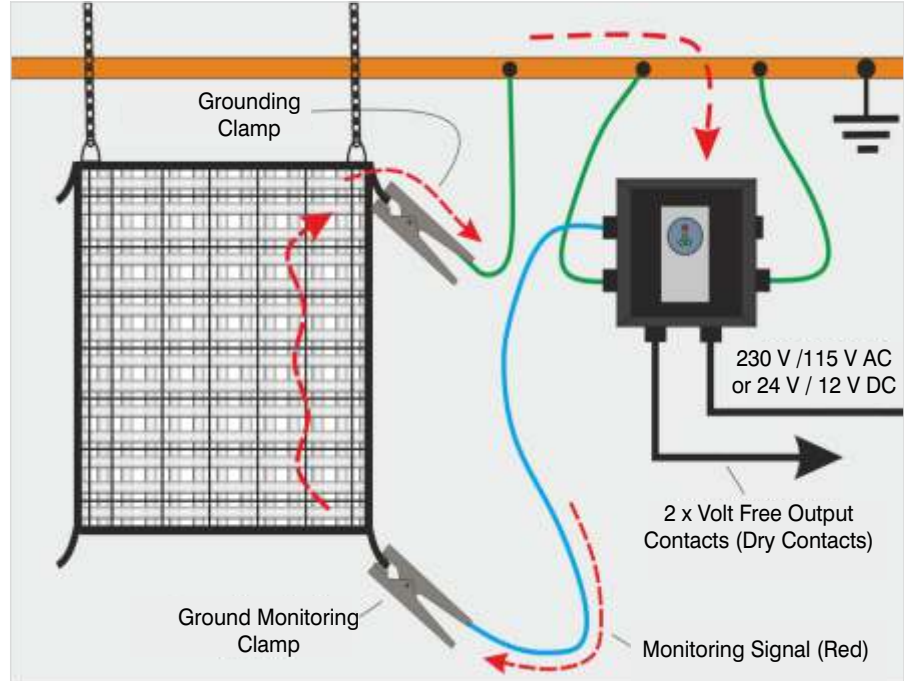

Likewise, if a company is committed to using IEC / NFPA 77 compliant 10 meg-ohm bags the permissive range of resistance to which the grounding system should be monitoring should be 0 ohms up to 10 meg-ohms.

**Ensure the grounding system you select is specific to the type of bag in use on site.**

If a grounding system is selected that monitors a narrow range of resistance, for example, monitors from 0 ohms up to 50 meg-ohms, this creates a problem and this problem could have two outcomes.

The first is that if 10 meg-ohm bags are specified for the site, the system could pass faulty bags as it will pass any bag that shows a resistance from 10 meg-ohms up to 50 meg-ohms. A direct consequence of this

feature is that it could be passing bags not manufactured in accordance with IEC-61340-4-4 and the recommendations of NFPA77.

The second outcome is if 100 meg-ohm bags are specified for the site. As the grounding system has a cut-off resistance of 50 meg-ohms, it will fail any bag that is operating between 50 meg-ohms and 100 meg-ohms. A direct consequence of this problem is that the system could reject a bag that is perfectly adequate and result in delayed operations while the operators are replacing the bag.

It is, therefore, of paramount importance to determine what types of Type C bags the site will be using. On that basis the site can select a system that will monitor the full range of 10 meg-ohm bags or a select a system that will monitor the full range of 100 meg-ohm bags.

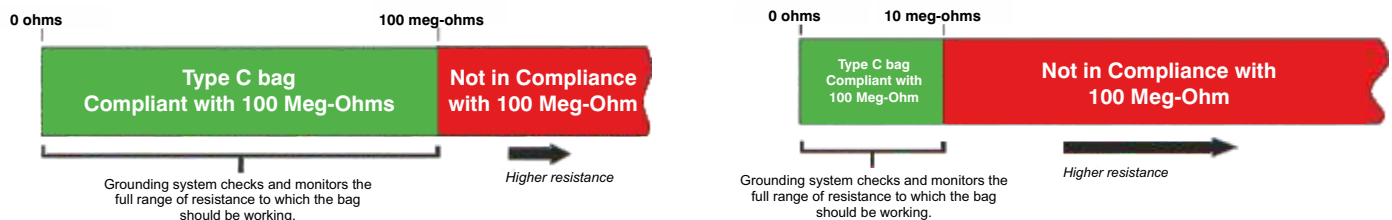

**Earth-Rite® FIBC** Static grounding protection for Type C FIBC located in potentially flammable/combustible gas or dust atmospheres



**Contact Us >** Your inquiry will be processed rapidly via our webform enquiry service. If you would prefer to call us, or e-mail us, please use the contact details provided below.

**Product Ordering Codes** \* Additional Options Available

Ordering Code	Product Description	IECEX / ATEX	North America
<b>FIBC8P1EA1A1</b>	ER FIBC 1 x 10 <sup>3</sup> monitoring system + X45F stainless steel clamp + 5 m (16 ft.) Hytrel Cable + junction box with Quick Connect.	•	
<b>FIBC8P1UA1A1</b>	ER FIBC 1 x 10 <sup>3</sup> monitoring system + X45F stainless steel clamp + 5 m (16 ft.) Hytrel Cable + junction box with Quick Connect.		•
<b>FIBC7P1EA1A1</b>	ER FIBC 1 x 10 <sup>7</sup> monitoring system + X45F stainless steel clamp + 5 m (16 ft.) Hytrel Cable + junction box with Quick Connect.	•	
<b>FIBC7P1UA1A1</b>	ER FIBC 1 x 10 <sup>7</sup> monitoring system + X45F stainless steel clamp + 5 m (16 ft.) Hytrel Cable + junction box with Quick Connect.		•
<b>FIBC8MEA1A1</b>	ER FIBC Exd 1 x 10 <sup>8</sup> monitoring system + X45F stainless steel clamp + 5 m (16 ft.) Hytrel Cable + junction box with Quick Connect.	•	
<b>FIBC8MUA1A1</b>	ER FIBC XP 1 x 10 <sup>8</sup> monitoring system + X45F stainless steel clamp + 5 mtr. (16 ft.) Hytrel Cable + junction box with Quick Connect.		•
<b>FIBC7MEA1A1</b>	ER FIBC Exd 1 x 10 <sup>7</sup> monitoring system + X45F stainless steel clamp + 5 m (16 ft.) Hytrel Cable + junction box with Quick Connect.	•	
<b>FIBC7MUA1A1</b>	ER FIBC XP 1 x 10 <sup>7</sup> monitoring system + X45F stainless steel clamp + 5 m (16 ft.) Hytrel Cable + junction box with Quick Connect.		•

**United States**  
 Newson Gale Inc  
 460 Faraday Avenue  
 Bldg C  
 Jackson, NJ 08527  
 USA  
 +1 732 961 7610  
 groundit@newson-gale.com

**United Kingdom**  
 Newson Gale Ltd  
 Omega House  
 Private Road 8  
 Colwick, Nottingham  
 NG4 2JX, UK  
 +44 (0)115 940 7500  
 groundit@newson-gale.co.uk

**Deutschland**  
 Newson Gale GmbH  
 Ruhrallee 185  
 45136 Essen  
 Deutschland  
 +49 (0)201 89 45 245  
 erdung@newson-gale.de

**South East Asia**  
 Newson Gale S.E.A. Pte Ltd  
 136 Joo Seng Road  
 #03-01  
 Singapore  
 368360  
 +65 6704 9461  
 ngsea@newson-gale.com